

TOOLS FOR BUILDING HEALTHY SOIL



**Compost,
Mulch and More**

Healthy soil is the foundation of a beautiful, bountiful garden. Composting, sheet mulching and cover cropping are a few practices that will improve your soil. This guide can help you get started at home.

TABLE OF CONTENTS

Building Healthy Soil	3
Backyard Composting	5
Worm Composting	15
Compost Bins & Designs	19
Sheet Mulching	25
Cover Cropping	28
Community Resources	30



BUILDING HEALTHY SOIL



In a garden, you are growing two things: plants and the soil. Of the two, many gardeners focus on growing the soil, knowing that healthy plants will follow. Like humans, plants require certain nutritional elements for optimal growth and health. Some of these – carbon, hydrogen, and oxygen – they take from air or water. The rest come from the soil.

There are three primary nutrients that plants need: nitrogen, phosphorus, and potassium. These are the N, P, and K, respectively, that one sees on fertilizer packages. A plant needs more of these elements than any other, so they have to be more frequently replenished in the soil. Each supports a particular function, such as the growth of leaves (nitrogen), the formation of fruit (potassium), and the ripening of seeds (phosphorus). There are three secondary nutrients (calcium, magnesium, and sulfur) and fourteen micronutrients.

The purpose of building your soil is to provide plants with the nutrients that are essential to their health and growth. Using soil tests, plant appearance, intuition, and experience, gardeners can identify which nutrients are needed. Having determined what nutrients plants need, gardeners must also give thought to how those nutrients will be provided. It is always better to feed the soil with compost, mulch, cover crops, aged herbivore manure, or worm castings, than to feed the plant alone with quick release fertilizers that can destroy soil life.

In addition to nutrients, gardeners must also consider the soil's basic make-up and texture. Every gardener's ideal is a soil called loam. Dark and wonderfully crumbly, a good quality loam has high organic content, is teeming with life, contains all the nutrients that plants need, holds moisture well, and drains well. The preferred method for improving soil structure over time is mulching or top dressing with organic materials.

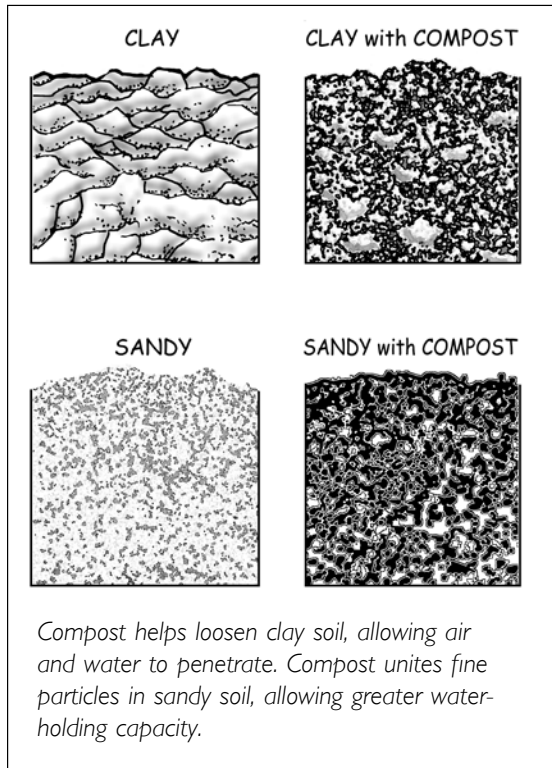

Urban soils have often been compacted, eroded, and depleted. Using compost and mulch helps restore the soil's ability to grow healthy plants naturally and to absorb more water, which reduces the need for irrigation and helps control erosion. Soils high in organic matter are also rich in slow release nutrients that promote plant growth without depending on chemical fertilizers. **This booklet provides information to help you get started building healthy soil in your garden.**

BACKYARD COMPOSTING

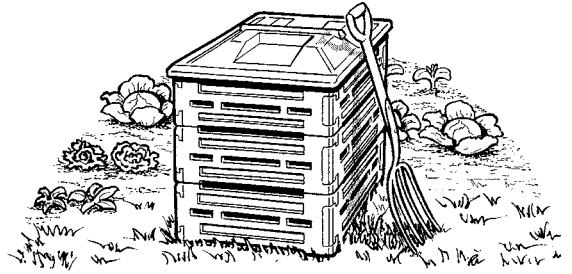

Composting is nature's way of recycling. It is a satisfying way to turn your fruit, vegetable and yard trimmings into a dark, crumbly, sweet-smelling soil conditioner.

Composting:

- Improves the fertility and health of your soil.
- Saves water by helping the soil hold moisture.
- Increases crop yields.
- Recycles valuable organic resources and keeps them out of landfills.

Not only does composting help the environment, but it can help your garden, yard, and house plants too! When compost looks like soil and smells sweet and earthy, it is ready to use. Backyard composting is suitable for food and yard trimmings in rodent-resistant bins, and just yard trimmings in open piles or simple bins.

Before getting started it is important to consider what you will be composting — food trimmings, yard trimmings, or food mixed with yard trimmings.



DECIDING WHAT TO COMPOST

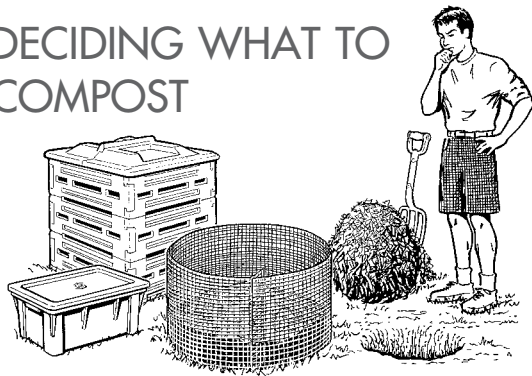

SYSTEMS FOR FOOD & YARD TRIMMINGS

Rodent-Resistant Bins

To be rodent resistant, bins require a lid, floor and no opening greater than 1/4". They are best for composting fruit, vegetable and yard trimmings. A good bin can help prevent rodents from nesting in your pile.



SYSTEM FOR YARD TRIMMINGS ONLY

Open Piles & Simple Bins

Open piles and simple bins should be used for yard trimmings ONLY. Actively maintain these systems by chopping and turning frequently to keep animals out.



SYSTEM FOR FOOD TRIMMINGS ONLY

Worm Bins

Worm bins can be placed indoors or outdoors and produce excellent fertilizer. See the Worm Composting section on page 15 for more information.



Remember: Whenever you compost fruit & vegetable trimmings, the County Environmental Health Department requires a rodent-resistant system with a lid, a floor, and no opening greater than 1/4".

GETTING STARTED

Thanks to beneficial bugs and worms, composting is as easy as "1, 2, 3" — no matter which recipe you use!

1. Chop materials to help them to break down more quickly.



2. Mix "browns" (dry, woody materials) with "greens" (moist, green materials).



3. Maintain air & water balance by keeping compost as moist as a wrung-out sponge.

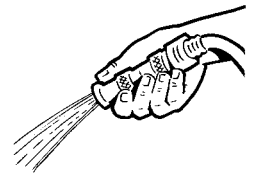

Browns, Greens, Air and Water are the "big four" that will keep every compost pile happy.



DO COMPOST:

- Fallen leaves
- Chopped, woody prunings
- Pine needles
- Sawdust from untreated wood
- Fruit & vegetable trimmings
- Lawn clippings
- Weeds without seed heads
- Coffee grounds & filters
- Citrus rinds
- Tea bags
- Herbivore manures & bedding

DON'T COMPOST*:

- Grains, beans or breads
- Sawdust from plywood/treated wood
- Meat, bones or fish
- Dog, cat or bird feces
- Diseased plants (in cold piles)
- Dairy products or grease
- Large amounts of soiled paper, pizza boxes
- Bio-plastics labeled “compostable”

***NOTE:** Many of these items can be put in your green waste bin for commercial-scale composting. Check with your local recycling provider to see what can go in your green bin.

A Word in Favor of Green Bins.

Green bins are a great way to compost organic materials that aren't suitable for your backyard bin. For example, soiled paper, dairy products and grains can all go in your curbside green bin, but can be problematic in your backyard bin. All cities in Alameda County provide curbside pick-up of compostable materials. You can purchase finished compost at multiple locations and some cities have free “give-back” programs. Visit www.stopwaste.org for more information.

Hot compost

happens when you follow the basic “1-2-3” carefully, and the pile is at least one cubic yard (3'x3'x3'). Heat can accelerate composting and kill weed seeds and plant diseases, but it is not necessary. Cold, slow piles are just as good. If your pile is large enough, moist, and well chopped, but is still not heating up, you can turn it and mix in some greens like grass clippings. For faster hot composting and better weed-seed kill, turn or mix your hot pile about once a week.



RECIPES FOR RODENT-RESISTANT BINS

“NO-FUSS” COMPOST

For yard trimmings ONLY. Requires a rodent-resistant bin to prevent animal nesting.

Ingredients:

Yard trimmings only (browns & greens),
water as needed



Directions:

- 1. Feed** chopped or unchopped yard trimmings into bin as you generate them.
- 2. Maintain** compost by keeping it as moist as a wrung-out sponge.
- 3. Harvest** rich, brown, finished compost from the bottom and center of the pile after 12 to 18 months.

“MIXED” COMPOST

For fruit, vegetable & yard trimmings together. This recipe requires a rodent-resistant bin and active maintenance to prevent animal nesting and feeding.

Ingredients:

Fruit, vegetable and yard trimmings (browns & greens), water as needed.



Directions:

1. Feed yard trimmings to your pile as you generate them by chopping them first into pieces 6” or smaller. Food scraps need to be buried and mixed into the center of the pile. Never dump food and run! Be sure to mix in enough browns to balance your greens. Feed as often as you like and always top with browns.

2. Maintain compost by turning or mixing it about once a week. Keep it as moist as a wrung-out sponge.

3. Harvest rich, brown, finished compost by sifting out coarse, unfinished materials after 3 to 8 months.

“ACTIVE” COMPOST

For yard trimmings ONLY. In open piles & simple bins, active maintenance prevents animal nesting.

Ingredients:

Yard trimmings only (browns & greens), water as needed



Directions:

1. Feed yard trimmings to the pile after chopping them into pieces 6” or smaller, then mixing them into the pile. Feed as often as you like. Be sure to balance browns with greens.

2. Maintain pile by turning or mixing it about once a week. Keep it as moist as a wrung-out sponge. Covering it with a plastic tarp will help keep it moist.

3. Harvest a rich, brown, finished compost by sifting out coarse, unfinished materials after 3 to 8 months.

HARVESTING COMPOST

How to tell when compost is done

- Original materials are unrecognizable, except some persistent woody materials
- Pile is 30-50 percent lower in volume
- Dark, loose, crumbly and has a sweet earthy smell

Storing Compost

We recommend “aging” your compost by letting it sit for 6 months before using. Cover with a tarp or keep in a protected environment to protect from the rain and sun. Remove the tarp periodically to provide air.

NOTE: If unfinished compost is added to your soil, the decomposer organisms compete with plants for nitrogen resulting in stunted plant growth and yellow leaves.

USING COMPOST

Compost is a slow release amendment which adds vital organic matter to the soil. Following are the most common applications for using compost.

1. Amending soil before planting
2. Mulching or topdressing in planted areas
3. Adding to potting mixes

Soil Amendment

Before planting, mix a 4" to 8" layer of compost into newly reclaimed or poor soils. Mix a 1/2" to 3" layer of compost into annual garden beds at least once a year, and more if you are doing multiple plantings. Add compost to perennial beds when planting and topdress at least once a year.

Mulch or Topdressing

Spread a 2" layer of coarse compost on soil as a mulch, or spread a 1/2" layer of sifted, weed-seed-free compost on turfgrass as a topdressing. These can be done any time of year to improve soil fertility and reduce watering needs.



Potting Mixes

Sifted compost can be used to make a rich, loose potting soil for containers, houseplants or starting seedlings from scratch.

Compost or vermicompost potting mix increases moisture storage and provides a variety of nutrients not typically supplied in commercial fertilizers or soil-free potting mixes.



NOTE: Do not use pure compost as a planting medium; it should always be mixed with other materials.

Recipe for starting seedlings:

- Sift compost through a 1/2 inch or smaller mesh.
- Mix 1 part sifted compost, 1 part fine sand (available at nurseries) and 2 parts garden soil.
- Use compost tea (see next page) when true leaves emerge.

Recipes for containers and house plants:

- Sift compost through 1/2 inch mesh screen or remove large particles by hand.
- Mix equal parts loamy soil, sand and compost. Add 1/2 cup of bloodmeal or cottonseed meal.
- Add 1 cup of rock phosphate and 1/2 cup of kelp meal for additional nutrients.



Compost Tea

Compost tea is rich with microbes and is excellent for plant growth promotion and disease prevention. It can also be used as a soil drench, as a foliar spray or to soak seeds to increase their germination rate.

Fill a five-gallon bucket 1/3 full with finished compost (either worm or backyard).

Fill the remainder of the bucket with non-chlorinated water (ideally). Let it brew for a few days, stirring every day to add oxygen or use an aquarium bubbler for 24 hours. Filter off the liquid tea and dilute the mixture to a light amber color if it is very dark.



NOTE: the liquid that comes from your worm bin is not compost tea, but a leachate that can be harmful to your plants.

Symptoms

Problems

Solutions

Pile not composting	Too dry Too much brown matter	Add water until slightly damp & turn (mix) Add fresh green matter or organic nitrogen fertilizer & turn
Pile smells rotten/attracts flies	Too wet/too many food scraps or lawn clippings Food scraps exposed Non-compostables	Turn & add browns (dry, woody materials) or dry soil Bury & mix food scraps into pile Remove meat, dairy, grease, etc. & turn
Rodents in pile	Food scraps in open bin/holes larger than 1/4 inch/non-compostables	Use traps or baits, rodent-proof bin, remove meat, grease, etc. & turn

WORM COMPOSTING

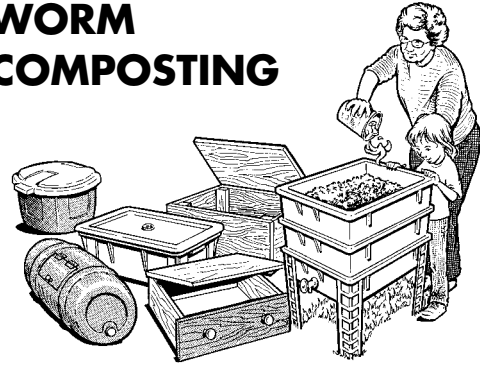

Worm composting is a great way to turn your fruit and vegetable scraps into a quick release fertilizer. A pound of red worms can eat 65 pounds of food trimmings in less than three months!

Getting Started

1. Choose a bin. Buy a bin, or build one out of wood, plastic, an old dresser drawer, shipping crate, or barrel. Your bin needs to be 10"-16" deep, have a snug-fitting lid, and holes on the sides for ventilation. To keep rodents out, the holes need to be 1/4" inch or smaller. The rule of thumb for bin size is two square feet of surface area per person. An average two-person house would need a bin about 2'x2' = 4 square feet, or two bins that are 1'x2' = 2 square feet each.

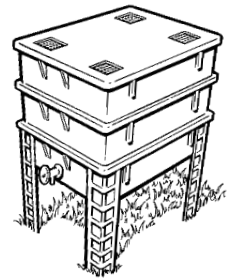

2. Pick a place. Locate your bin where it will not freeze or overheat — in a pantry, kitchen corner, laundry room, garage, basement, patio, deck, or in your garden.

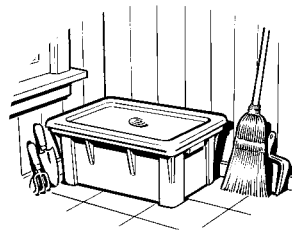

3. Make a worm bed. Worms like to live under lots of moist paper or leaves. This helps keep them cool and moist, gives them fiber to eat, and prevents fruit flies from getting to the food. To make your worm bed, tear black & white newspapers into one-inch strips, fluff them up, then moisten them so they are completely wet but not dripping. Fill your bins 3/4 full with this moist “bedding.” Shredded, corrugated cardboard, leaves, compost, and straw can also be added in as bedding. Sprinkle bedding with a few handfuls of soil. Do not use glossy paper or magazines.

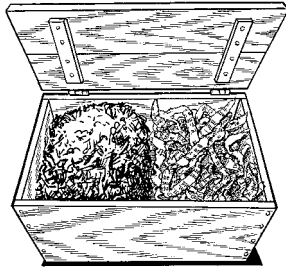

4. Adopt some worms. Compost worms are often called “red worms” or “red wigglers.” They are different from earthworms and nightcrawlers who live underground. You can get red worms from a friend’s worm bin or buy them from a worm farm (visit www.stopwaste.org for a list of worm sources). Start with one half to one pound of worms, or two nice big handfuls.

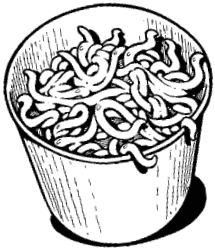

5. Feed worms their first meal. Start your worms off with about a quart of fruit and vegetable trimmings. Then leave them alone for a couple of weeks while they get used to their new home.

Maintaining Your Worm Bin

Feed your worms about a quart (one pound) of food scraps per square foot of surface area in your bin per week. To avoid fruit flies and odors, always bury food under the bedding. Don’t dump and run!

Add fresh bedding every time you feed the worms. Always keep a 4” – 6” layer of fresh bedding over the worms and food in your bin.



Keep bedding as moist as a wrung-out sponge. In a plastic bin, add dry bedding to absorb excess moisture. Wooden bins may require adding water occasionally.

Harvesting & Using Worm Compost

Harvest worm compost at least once each year to keep your worms healthy. You can start harvesting 2-3 months after you set up your bin. Simply reach in and scoop out the brown crumbly compost, worms and all. You can also move the contents of your bin to one side, place fresh bedding and a handful of soil in the empty space and bury food there for a month or two. Harvest the other side after the worms have migrated to the new food and bedding. It’s best to use castings soon after you harvest or store in a plastic bag to keep the castings moist.

Using worm compost will help your plants thrive by adding nutrients and humus to the soil. Sprinkle a 1/4” to 1” layer at the base of indoor or outdoor plants, or blend no more than 20% worm compost into potting mix or garden soil. Add water to worm castings at a 10:1 ratio and use on plants and trees.

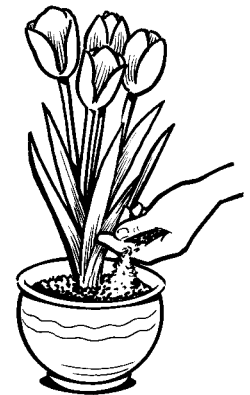

Symptoms

Problems

Solutions

Worms are dying

Food and bedding all eaten
Too dry
Extreme temperatures

Harvest compost, add fresh bedding & food
Add water until thoroughly moistened
Move bin so temp. is between 40-80° F

Bin attracts flies and/or smells bad

Food exposed/overfeeding
Non-compostables present

Add 4"-6" layer of bedding & stop feeding for 2-3 weeks
Remove meat, pet feces, etc.

Sowbugs, beetles in bin

These are good for your worm compost!

COMPOST BINS & DESIGNS

It is important

to know what you want to compost when choosing your bin system.

Please see the tips below for different compost systems.



	WORM BIN	BACKYARD ENCLOSED BIN
MATERIALS TO COMPOST	Food waste only	Food waste and yard waste
PROS	Requires little space Can use indoors or outdoors	Can compost both yard and food waste
CONS	No yard waste Do not put in direct sun Can require troubleshooting	Most designed for "cold piles" Must have volume of 3'x3'x3' (1 cu yd) in order to make a hot pile.
NOTES	Make a worm bin by drilling holes in a 10-16" deep plastic storage bin. A tiered bin in which worms migrate from one level to the next makes harvesting easier. For purchased bins, check for sturdiness of legs and snugness of lids.	Add a ¼" or smaller wire mesh base to make a bin rodent resistant. Check bin for sturdiness. Harvesting a bin from a "door" can be complicated. Look for a bin that is easy to disassemble and reassemble.

BUILD YOUR OWN BIN

You can make a compost bin at home. Choose a system that fits your needs and follow the building directions.

NOTE: If you don't want to make your own bin, commercial bins can be purchased at local nurseries, hardware stores or online. For more information visit www.stopwaste.org.

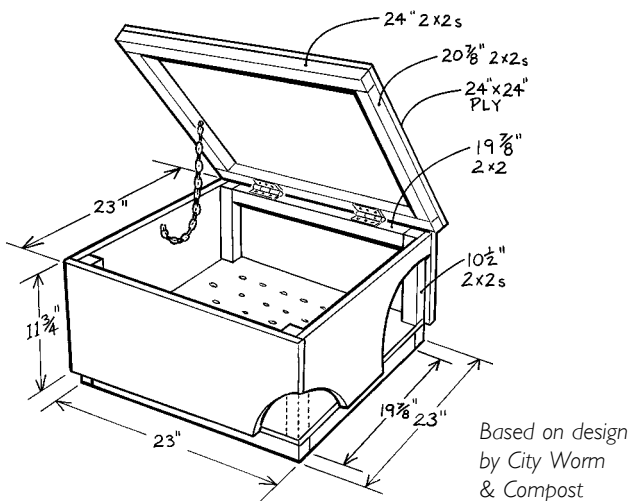

WOODEN WORM BIN

- For family of 2
- Basic carpentry skills needed for construction
- Doubles as a seat!
- Breathes well — will need occasional watering

Materials

- (1) 4'x4' piece exterior grade plywood
- (3) 6' pieces 2"x2" wood
- (1) 4' piece 2"x4" wood
- 1 pound 4-penny galvanized nails
- 16" light chain with (2) 1/2" wood screws
- (2) 2" hinges, with 3/4" wood screws
- Waterproof wood glue

Tools

Power saw (use eye protection) or hand saw, hammer, measuring tape, pencil, square, drill with 1/4" and 3/32" bits, sandpaper.

Assembly

(Glue all wood pieces before nailing)

Base: Nail the two 23" 2x4s and two 19-7/8" 2x2s to bottom of 23x23" plywood as drawn. Drill several 1/4" holes for drainage.

Side, Front and Back Walls: Nail the four 2x2 uprights to the two side walls along the 11-3/4" edge, with one end of each 2x2 flush with the top edge of the walls. Nail a 19-7/8" 2x2 hinge support to the top edge of the back wall piece, leaving 1-1/2" on each side for 2x2 uprights. Assemble box by nailing the 1-1/4" overhang of the side walls to the 2x2s on the base as drawn. Then nail the front and back walls to the 2x2 uprights and to the 2x4s on the base as drawn. Be sure the hinge support is at the top of the bin.

Lid: Nail lid together as drawn. Attach to box with hinges, making sure to pre-drill screw holes into the 2x2s, and position hinges as in detail. Attach chain with 1/2" wood screws so lid can rest in an opened position.

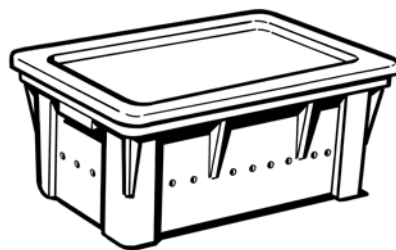

PLASTIC WORM BIN

- Composting system: fruit and vegetable trimmings alone
- Very easy to build; tidy for indoor use

- Plastic bins keep compost moist — will require regular additions of dry bedding
- \$6 - \$20 for new materials

Materials

(1) Plastic storage container with a tight fitting lid - 12" to 18" tall, 12"x24" base

Tools

Power drill (1/4" bit) or utility knife

Assembly

For indoor use, drill several holes for ventilation about halfway up the sides of the bin. For outdoor use, holes can be drilled in the bottom for ventilation and drainage. To reduce fly infestation, keep holes small.

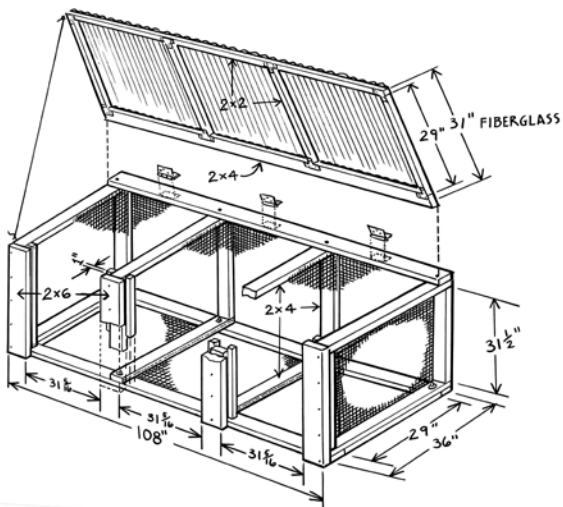

3-BIN WOODEN BIN

- Excellent for hot-composting—has removable front slats for easy turning, and separate bins for turning and aging compost, and/or storing compostables
- Can handle large amounts of compostables
- Requires minimum 3'x9' of yard space
- Carpentry skills needed for construction

Materials

- 2x4" wood*: (8) 31 1/2", (8) 36", (4) 9', and (4) 29" pieces
 - 2x6" wood: (4) 36" pieces
 - 2x2" wood: (6) 34 1/2", (1) 9', and (4) 29" pieces
 - 1x6" wood: (19) 31" pieces
 - 1/4" mesh hardware cloth: 30'x3'
 - Carriage bolts (3-1/2"x3/8"): 12, with washers and nuts
 - 12 penny galvanized nails: 2 pounds
 - 8 penny galvanized nails: 1 pound
 - Poultry wire staples: 1 pound
 - Corrugated fiberglass (4 oz.): (2) 8'x26" pieces
 - Gasketed roofing nails: (40)
 - Wiggle molding: 18 feet
 - 3" hinges (zinc plated, galvanized or brass): (3)
 - 4" flat corner braces: (4) with 1" wood screws
 - 4" flat "T" braces: (4), with 1" wood screws
 - (4) hook eyes, and 8' of strong twine or chain
- * You can make a two bin composter for a smaller yard by carefully adapting the materials list, drawings, and assembly instructions.

Tools

Power saw (use eye protection) or hand saw, drill with 3/8" and 1/16" bits, screwdriver, hammer, tin snips, tape measure, pencil, socket or wrench, carpenter's square.

Assembly

Main structure: Butt nail two 31 1/2" and two 36" 2x4s together with 12 penny nails to form each of four screen dividers. Cut four 36x33 1/2" wire mesh pieces, and staple (every 4") to frames after checking frames for squareness. Bolt dividers to three 9' 2x4s as shown (inside measurement between dividers should be 31 5/16"). Tack in 29" 2x4s as shown. Staple one 9'x3' piece of wire mesh (every 4") to back of structure, and one 9'x3' piece to the bottom.

Slats and slat tracks: Nail 2x6s to front of dividers. Nail 34 1/2" 2x2" onto frames as shown. Leave at least 1" for the slats to slide in. The last slat of each bin section needs to be cut lengthwise to fit.

Lid: Assemble lid frame as shown, with flat corner and "T" braces on the bottom side. Pre-drill nail holes every couple of feet into wiggle molding humps, and attach molding to 9' 2x2 and 9' 2x4 with 8 penny nails. Note position of wiggle molding on 2x4 in drawing. Cut fiberglass into five 32" pieces with tin snips. Pre drill fiberglass and wiggle molding on top of every third hump, and nail together with gasketed nails. Be sure to overlay fiberglass pieces at least one channel wide, and before attaching the last piece, trim off excess fiberglass. Attach lid to frame with hinges. Attach heavy duty twine or chain to lid and main frame with hook eyes as shown (to prevent lid from falling all the way back).

SHEET MULCHING



Sheet mulching is a layered mulch system that can be used to suppress weeds, build soil health and replace lawns.

There are many recipes for sheet mulching, which is a technique developed in permaculture. For a detailed description and case study of lawn removal with sheet mulch, visit www.stopwaste.org.

GETTING STARTED

Here's a simple recipe for sheet mulching at home. Many Bay Area landscape professionals are also using this method of sheet mulching in residential and commercial landscapes.

I. Prep the Site

Knock down or mow existing vegetation so it lies flat. Remove only woody or bulky plant materials. Soak area with water to start the natural process of decomposition.



Please note that there are some plants that need to be removed before sheet mulching because of their persistent invasive nature – plants that spread by rhizomes, bulbs or plants that can resprout from extensive root systems.

Common examples include: blackberries, oxalis, kikuyu and Bermuda grasses, horsetails.

To avoid mulch spilling over existing hardscaping, be sure to shovel around the edges so that the soil is at least 3 inches below the grade. The excess soil can be mounded away from the edges and sheet mulched in place. If you're sheet mulching a lawn, just flip the edges so the roots and soil are face up. Plants that prefer well-drained soils work well on mounds, e.g., natives, and it creates some visual interest in the garden.

2. Plant large plants

Plant 5 gallon or larger plants. Smaller plants will be planted after the weed barrier, compost and mulch are added.



3. Add a weed barrier

It is essential that this organic barrier is permeable to water and air. Do not use plastic. Do not use weed cloth. Recycled cardboard – from boxes, rolls, or thick layers of newspaper work particularly well.



Overlap pieces 6-8 inches to completely cover the ground except where there are established plants you want to cover. Wet down the cardboard as you go to keep it in place and make it easier to shape around obstacles.

4. Layer with compost and mulch

Compost can be spread directly over the weed barrier and covered with bulkier materials such as chipped tree prunings to optimize weed control. Adding compost helps build soil, but if your main goal is weed suppression, you can just add mulch.

The top layer of mulch mimics the newly fallen organic matter of the forest. In total, the compost/mulch layer should be 2-5 inches deep. Good materials for this layer include chipped plant debris, tree prunings, leaves or straw.

You can buy recycled arbor mulch or pallet mulch from multiple locations. Visit www.stopwaste.org for more information.

5. Plant

Punch or cut a hole in the cardboard and place plant in the soil under the sheet mulch. Smaller plants, e.g., 4 inch pots, can be planted right into the mulch/compost layer without cutting into cardboard. Add compost around rootball if compost is not included in the previous layer.



PREVENT POTENTIAL PROBLEMS

- As with any mulch, do not pile materials up against the trunks or stems of plants to prevent disease. Keep mulch at least one foot away from the foundation of your house.
- Especially during the dry season, small seedlings will need protection from snails and slugs that will seek cover under the mulch.
- Protect young trees from rodents with physical guards.
- Although it's preferable to sheet mulch in the fall to take advantage of the rains, it can be done any time of year.

Visit www.stopwaste.org for resources such as a mulch calculator, how-to videos and irrigation rebates to help with your sheet mulching project.

COVER CROPPING



Cover cropping involves

planting a green manure that will be worked in to feed and care for the soil. It is a very affordable way to improve your soil; the only expense is purchasing the seeds. Most gardeners use a blend of legumes, such as fava and bell beans, and grasses, such as oats and rye. Legumes have the ability to draw nitrogen from the air and incorporate it into their bodies and root systems. When they are cut down and worked into the soil the nitrogen is released and becomes available to other plants. Grasses provide a structure for the legumes to grow up, and add bulky organic matter when they are cut down.

Cover cropping is an important part of intensive vegetable gardening and can be included in edible crop rotations. Cover crops are usually sown in the fall in time for the rains, grown through the winter, and then cut down and worked into the soil in early spring. Most nurseries carry cover crop seed blends. Plan to use one to two pounds per thousand square feet of garden space. Ask your nursery if they carry microbial inoculants that can be used on legumes to encourage nitrogen fixation.

Cover cropping improves the soil by:

- Adding nitrogen and organic matter
- Protecting it from erosion
- Breaking up compaction

Cover cropping is a three step process:

1. Start by clearing out old crops and preparing a bed for planting.

2. Broadcast cover crop seed onto your garden beds in time for the fall rains in mid-to-late October. Sow about one to two pounds per thousand square feet. Use a rake or garden fork to work the seed in and cover it with soil. When the rains start the seeds will germinate and grow through the winter.

3. In the spring, when about a quarter of the legume's flower buds open, use garden shears to cut the cover crop down and then work it into the soil with a hoe or garden fork. It is best to cut the legumes down before they start using their stored nitrogen to make seeds. It will take a couple of weeks to a month for the crop residue to fully break down. You can leave the roots in place as that provides pore space for better drainage.

COMMUNITY RESOURCES

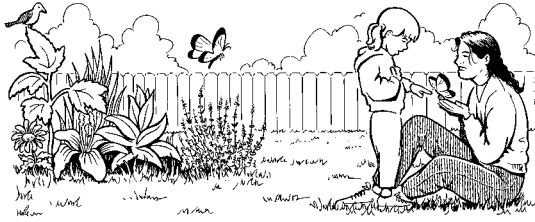

Cities, local agencies, and volunteer groups provide irrigation rebates, demonstration gardens, sources of free compost, and more to help make your garden more sustainable. Here are a few places to start looking for help in your community:

- City Public Works
- City Department of the Environment
- Municipal Stormwater Prevention Program
- Water District
- County Resource Conservation District
- County Master Gardeners
- Garden Club
- Local California Native Plant Society Chapter
- Community Gardens

StopWaste offers additional resources for Alameda County residents:

- Alameda County Recycling Hotline, 877-STOPWASTE
- Household Hazardous Waste, 800-606-6606
- Alameda County Recycling Guide and online database, www.recyclewhere.org

Visit www.stopwaste.org for more information.





1537 Webster Street
Oakland, CA 94612